

LIFTING SCREW POINT

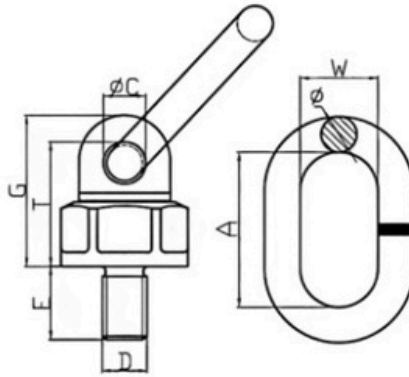

- Forged from high-strength, high-toughness special alloy steel and heat treated (quenched and tempered).
- Breakage Test: Strict sampling breakage tests are conducted on every batch of products.
- Surface Treatment: Powder coating.

ITEM NO.	WEIGH (kg)	WLL(T)		Torque (N.m)	DIMENSION(MM)						
		90°	0°		DxE	C±2	G±1	T±2	A±5	W±5	ø±1.5
8-UCM0105-M8X13	0.54	0.3	0.6	10-15	M8X13	16.5	53	42	55	30	14
8-UCM0105-M10X18	0.54	0.45	0.9	10-15	M10X18	16.5	53	42	55	30	14
8-UCM0105-M12X20	0.55	0.5	1	10-15	M12X20	16.5	53	42	55	30	14
8-UCM0105-M14X20	0.55	1.12	2	20-30	M14X20	16.5	53	42	55	30	14
8-UCM0105-M16X25	0.57	1.12	2	20-30	M16X25	16.5	53	42	55	30	14
8-UCM0105-M20X33	1.11	2	4	50-70	M20X33	19	68	56	70	35	16
8-UCM0105-M24X40	1.70	3.15	6.3	130-160	M24X40	22	78	65.5	85	40	18
8-UCM0105-M27X40	1.70	3.15	6.3	180-220	M27X40	22	78	65.5	85	40	18
8-UCM0105-M30X50(5T)	2.55	5.3	10.6	200-250	M30X50	23.5	97	81	85	40	20
8-UCM0105-M30X50(8T)	3.90	8	12.8	200-250	M30X50	28	113	93	115	50	22
8-UCM0105-M36X54	3.90	8	12.8	280-400	M36X54	28	110	90	115	50	22
8-UCM0105-M39X54	4.00	8	12.8	280-400	M39X54	28	110	90	115	50	22
8-UCM0105-M42X63	4.54	10	16	500-600	M42X63	28	110	90	115	50	25
8-UCM0105-M48X68	4.82	10	16	500-650	M48X68	28	110	90	115	50	25
8-UCM0105-M56X84	12.00	15	24	600-900	M56X84	42	165	133	152	70	32
8-UCM0105-M64X95	12.75	15	24	600-900	M64X95	42	165	133	152	70	32